

Product Brief

Micro SD Storage Card with embedded CPU

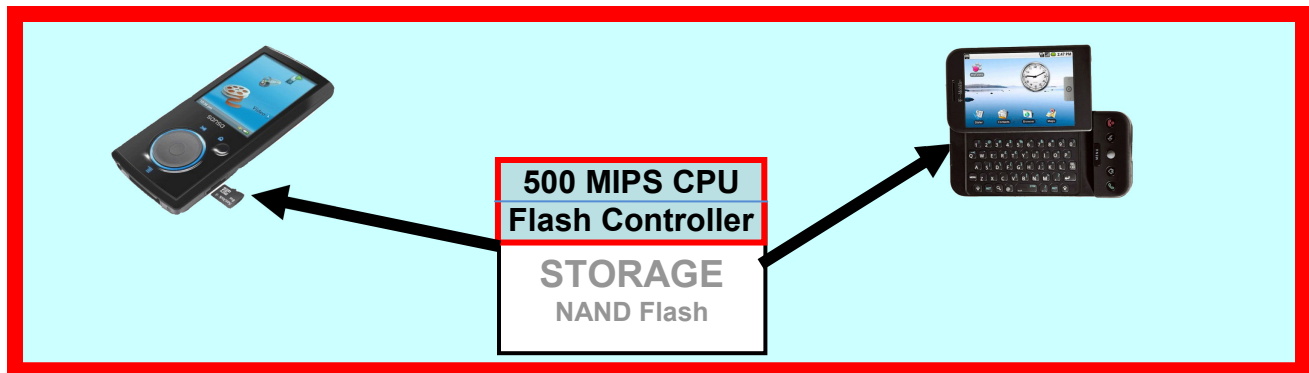

Mobile Semiconductor's proprietary computing and storage system, is delivered in an Micro SD format allowing easy addition of processing capability to 3G or 4G mobile handsets (smartphones) and similar mobile devices. Our technology can be used to upgrade a variety of mobile computing devices such as game players, advanced MP3 players, and E-Readers.

This product brief describes the capabilities of the MobileSD storage controller with embedded CPU. For detailed application information, contact Mobile Semiconductor Corporation.

Features:

- Advanced architecture solid state storage controller
- From 1 to 16 GigaBytes SLC or MLC NAND Flash
- Embedded Flash File System using standard SD interface
- 500 MIPS central processing unit (CPU) – equivalent to an iPhone.
- Proprietary caching mechanisms and direct access to data storage allows embedded CPU to offload the main processor
- Data encryption embedded in controller prevents attacks between the OS and storage layer

Applications:

- Low cost upgrade to devices adds new processing power
- Offloading the main CPU make multiple applications run smooth
- Programmable Data processor enables custom applications
- Secure connection between local storage and remote applications
- Application Interface (AI) and Software Development Kit (SDK) available

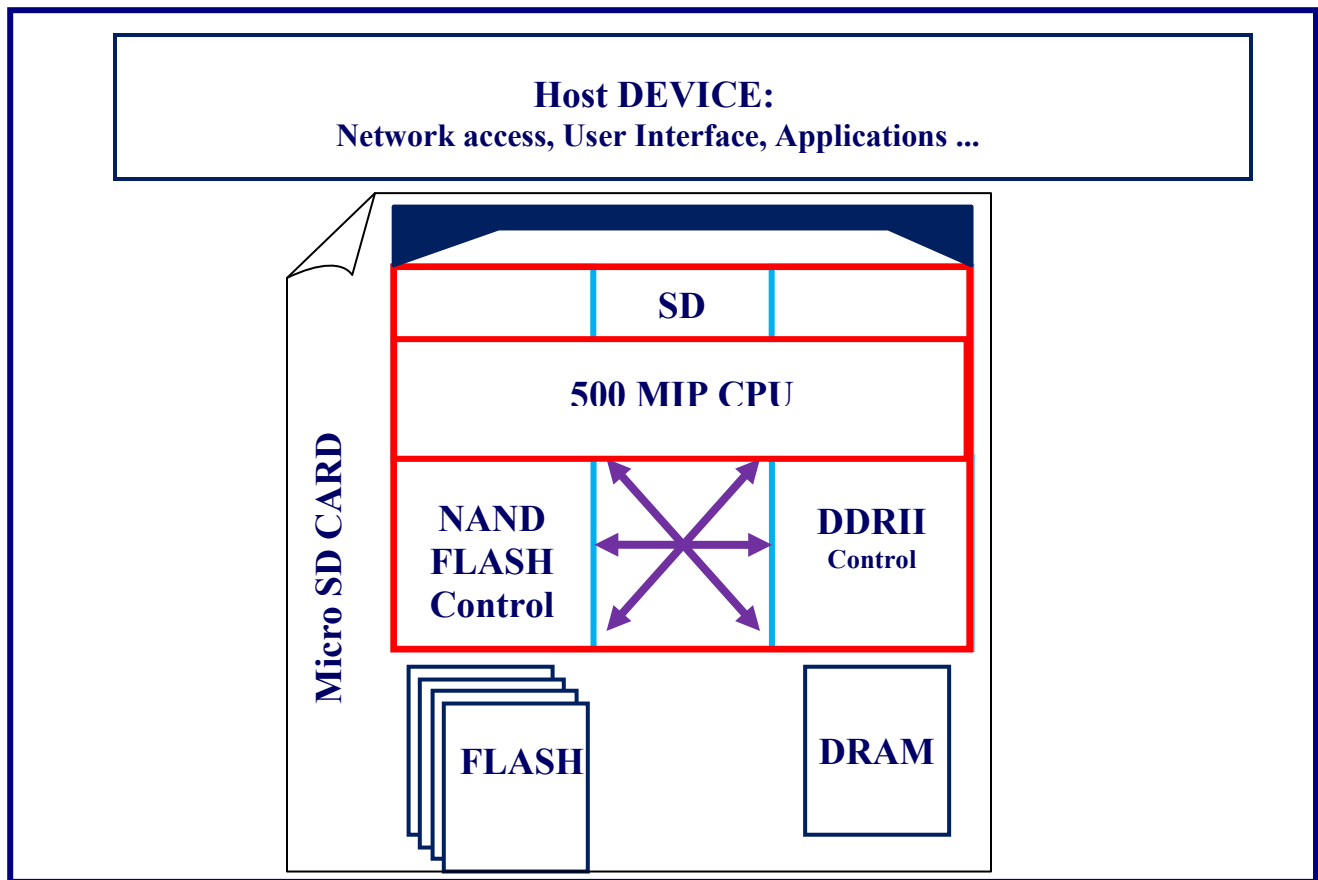

Figure 1 Controller Interface Ports

MobileSD is a high speed storage and computer system, combining NAND FLASH, Mobile DDR DRAM, and a memory controller in a single Micro SD card.

MobileSD provides a substantial performance advantage for application processing in mobile devices including smartphones, Mobile Internet Devices (MID), and E-Readers.

Standard operating system interface is provided to the embedded NAND as an SD storage device.

A specialized processor application interface (AI) port is available for applications running on the main processor to access the computing power on the SD device.

The sector based file system is compatible with multiple file systems including FAT and FAT32. For optimum performance and reliability, use of the transactional based file system, Datalight Reliance™ is recommended.

